

## **GPS & GLONASS Receiver (G-Mouse)**

**GT-502-EX-A**

**GT-502-EX-M**

## Directory

<b>Revision History</b> .....	2
<b>1. Product Information</b> .....	3
1.1 Product Description .....	3
1.2 Product Features .....	3
1.3 Product Specifications .....	4
1.3 DC Electrical Characteristics .....	5
<b>2. Physical Dimensions</b> .....	6
2.1 Pin Descriptions .....	6
<b>3. Software Interface</b> .....	9
<b>4. Protocol</b> .....	10
4.1 GGA-Global Positioning System Fixed Data .....	10
4.2 GLL-Geographic Position - Latitude/Longitude .....	11
4.3 GSA – GNSS DOP and Active Satellites .....	12
4.4 GSV - GNSS Satellites in View .....	13
4.5 RMC - Recommended Minimum Specific GNSS Data .....	14
4.6 VTG - Course Over Ground and Ground Speed .....	15

## 1. Product Information

### 1.1 Product Description

The GT-502-EX-A is a stand-alone UART interface GNSS receiver, featuring the high performance MediaTek positioning engine. It is flexible and cost effective receiver offers numerous connectivity options in a miniature enclosure 45x38x13 mm.

Through the feature of 99-channel, the GT-502-EX-A boasts a hot start in less than 1 second. Innovative design and technology suppresses jamming sources and mitigates multipath effects, assisting GT-502-EX-A GNSS receivers excellent navigation performance even in the most challenging environment.

### Applications

- Automotive Navigation
- Personal Positioning
- Fleet Management
- Marine Navigation

### 1.2 Product Features

- Build on High Performance, Low-Power MediaTek chipset
- Low Power Consumption: Max 45mA@3.3V
- Ultra High Track Sensitivity: -165dBm
- Built in High Gain LNA
- The built-in Super Capacitor for Backup Ephemeris
- Extremely Fast TTFF at Low Signal Level
- Communication Type: UART
- NMEA-0183 Compliant Protocol or Custom Protocol
- RoHS Compliant

## 1.3 Product Specifications

GPS Receiver		
Chip	MediaTek	
Frequency	Support 99 channels (33 Tracking, 99 Acquisition) GPS&QZSS L1 1575.42MHz C/A Beidou B1 1561.098MHz GALILEO E1B/C1 GLONASS L1OF 1602MHz SBAS: WAAS, EGNOS, MSAS, GAGAN	
Update Rate	1Hz (default) , up to 10Hz	
Position Accuracy	Position	<2.5m CEP @-130 dBm
	Accuracy of 1PPS Signal	Time pulse signal: RMS 30ns
	Acceleration Accuracy	Without aid: 0.1m/s <sup>2</sup>
Startup Time	Cold start	35s typ @-130dBm
	Warm start	30s typ @-130dBm
	Hot start	1s typ @-130dBm
Sensitivity	Acquisition	-146Bm
	Re-acquisition	-156Bm
	Tracking	-165dBm
GNSS Operating limit	Altitude	18,000m
	Velocity	515m/s
	Acceleration	4G
Protocol Support	UART Port: TXD and RXD 9600bps (default), Supports baud rate 4800bps to 460800bps NMEA 0183 Protocol	
Environment	Operation temperature	-40°C ~ +85°C
	Storage temperature	-45°C ~ +125°C
Physical Characteristics	Size	45±0.20 × 38±0.20 ×13±0.50mm
	Weight	Approx. 49g

## 1.3 DC Electrical Characteristics

Parameter	Min.	Typ.	Max.	Units
Input Voltage	3.0	3.3	5.5	Volt
Acquisition		45		mA
Tracking		40		mA
Backup Battery		15		uA
Low Level Output Voltage (VOL)			0.4	Volt
High Level Output Voltage (VOH)	2.4			Volt
Low Level Input Voltage (VIL)			0.8	Volt
High Level Input Voltage (VIH)	2			Volt
Low Level Output Current (IOL)		2		mA
High Level Output Current (IOH)		2		mA

## 2. Physical Dimensions

(Different Cables & Connectors can be Specified According to Requirements)

P/N	Mount	Description
GT-502-EX-A-N	Adhesive	No Connector, 5 Wire Open End
GT-502-EX-M-N	Adhesive + Magnetic	No Connector, 5 Wire Open End

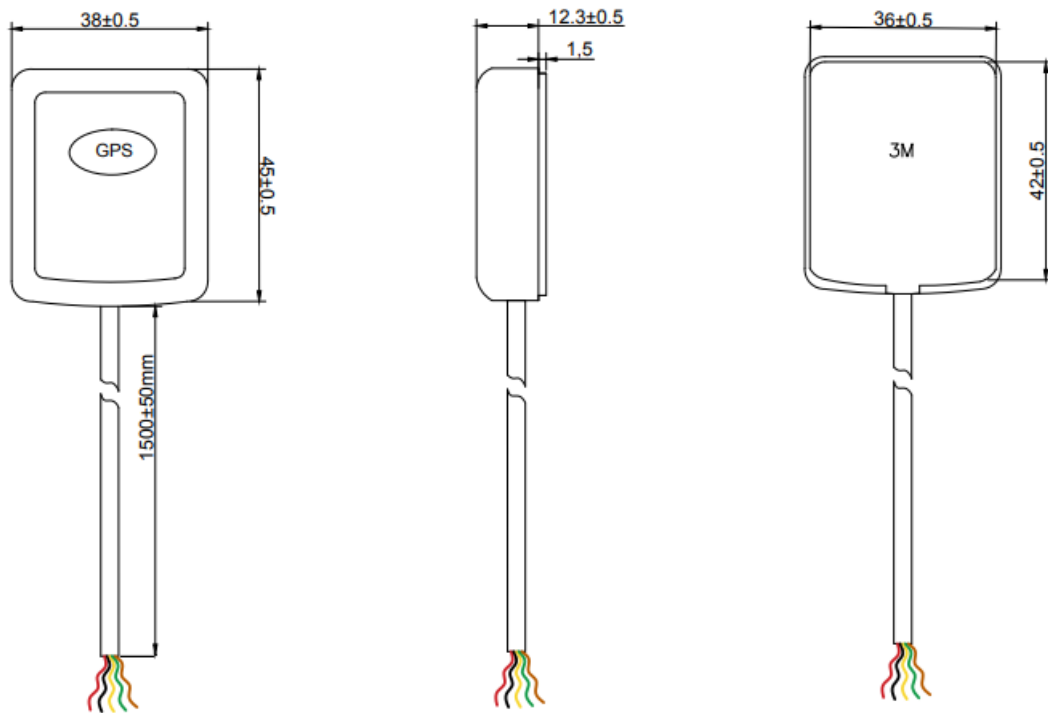

### 2.1 Pin Descriptions

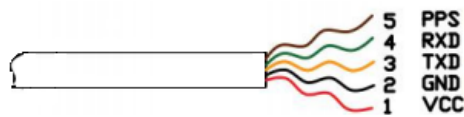

Pin NO.	Pin Name	Remark
1	VCC	Module Power Supply
2	GND	Ground
3	TXD	TTL Output
4	RXD	TTL Input
5	PPS	Time Pulse (1PPS) Output

P/N	Mount	Description
GT-502-EX-A-4ST25	Adhesive	(4 pin 2.5mm Earphone Jack)
GT-502-EX-M-4ST25	Adhesive+Magnetic	(4 pin 2.5mm Earphone Jack)
GT-502-EX-A-4ST35	Adhesive	(4 pin 3.5mm Earphone Jack)
GT-502-EX-M-4ST35	Adhesive+Magnetic	(4 pin 3.5mm Earphone Jack)

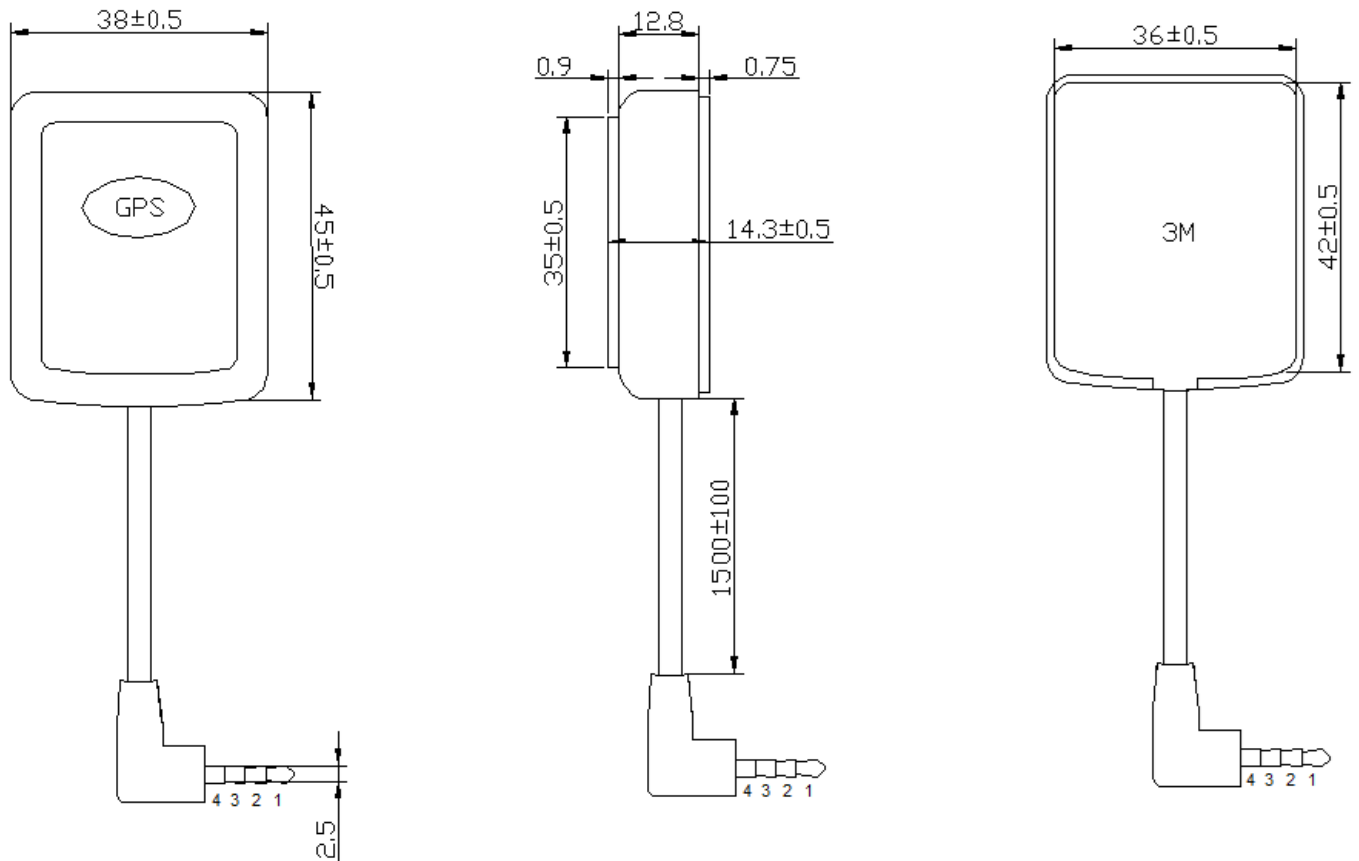

I/O Interface	Voltage level
4 pin 2.5mm Earphone Jack	UART(TTL level)
4 pin 3.5mm Earphone Jack	UART(TTL level)

Pin NO.	Pin Name	Remark
1	Vcc	3.0 - 5.0V DC
2	RXD	TTL input
3	TXD	TTL output
4	GND	Ground

P/N	Mount	Description
GT-502-EX-A-3ST25	Adhesive	(3 pin 2.5mm Earphone Jack)
GT-502-EX-M-3ST25	Adhesive+Magnetic	(3 pin 2.5mm Earphone Jack)
GT-502-EX-A-3ST35	Adhesive	(3 pin 3.5mm Earphone Jack)
GT-502-EX-M-3ST35	Adhesive+Magnetic	(3 pin 3.5mm Earphone Jack)

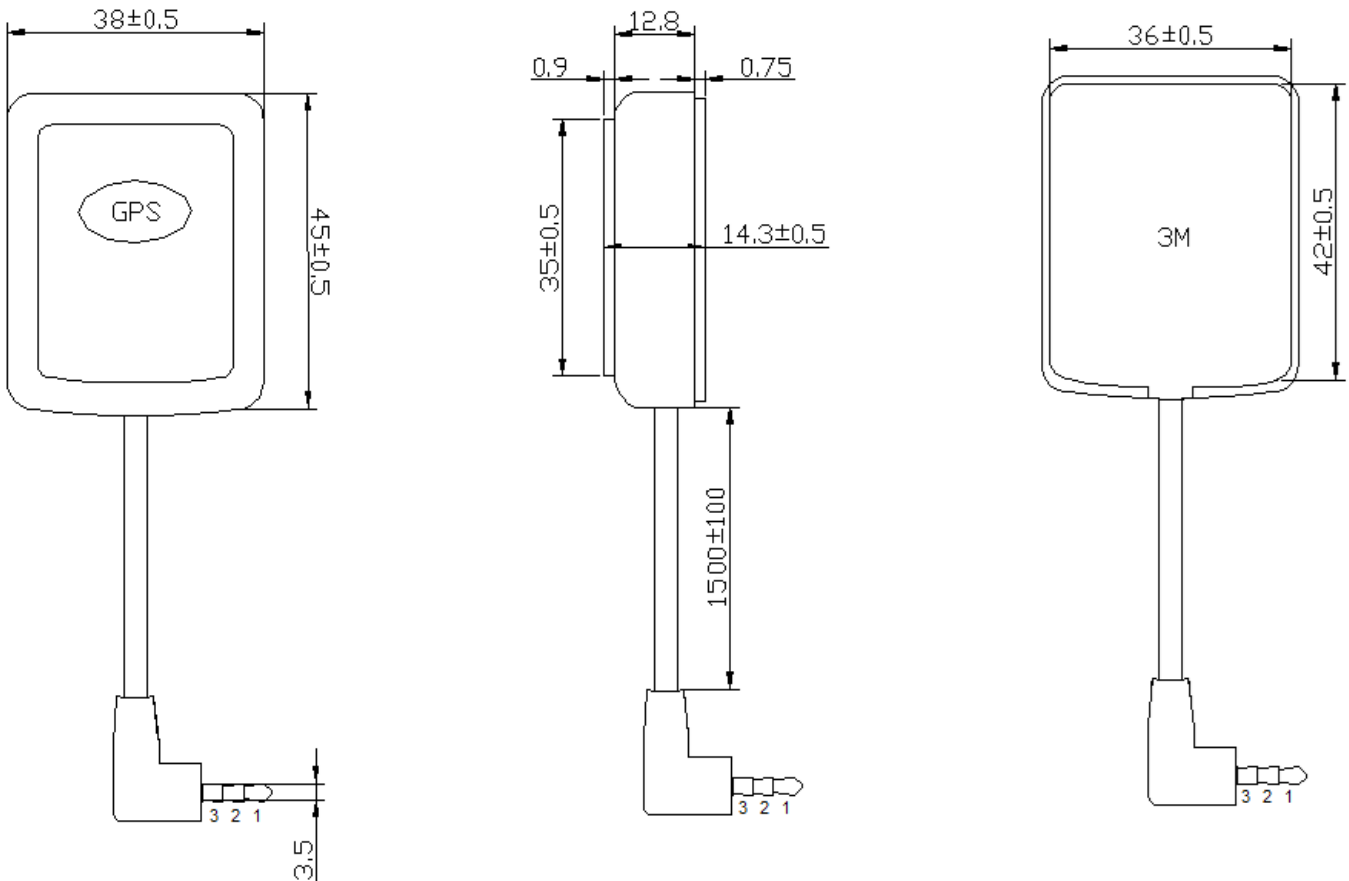

I/O Interface	Voltage level
3 pin 2.5mm Earphone Jack	UART(TTL level)
3 pin 3.5mm Earphone Jack	UART(TTL level)

Pin	Pin define	Level
1	Vcc	3.0 - 5.0V DC
2	TXD	TTL output
3	GND	Ground



## 3. Software Interface

NMEA	Description
GGA	GGA Global positioning system fixed data
GLL	GLL Geographic position—latitude/longitude
GSA	GNSS DOP and active satellites
GSV	GNSS satellites in view
RMC	RMC Recommended minimum specific GNSS data
VTG	VTG Course over ground and ground speed

## 4. Protocol

### 4.1 GGA-Global Positioning System Fixed Data

For example:

```
$xxGGA,161229.487,3723.24751,N, 12158.34160,W, 1,07,1.0,9.0,M.0000*18
```

Field	Name	Example	Units	Description
1	Message ID	\$xxGGA		GGA protocol header
2	UTC Position	161229.487		hhmmss.sss
3	Latitude	3723.24751		ddmm.mmmm
4	N/S indicator	N		N=north or S=south
5	Longitude	12158.34160		dddmm.mmmm
6	E/W Indicator	W		E=east or W=west
7	Position Fix Indicator	1		See Table 1-1
8	Satellites Used	07		Range 0 to 12
9	HDOP	1.0		Horizontal Dilution of Precision
10	MSL Altitude	9.0	meters	
11	Units	M	meters	
12	Geoids Separation		meters	
13	Units	M	meters	
14	Age of Diff.Corr.		second	Null fields when DGPS is not Used
15	Diff.Ref.Station ID	0000		
16	Check sum	*18		
17	<CR> <LF>			End of message termination

**Table 1-1: Position Fix Indicators**

Value	Description
0	Fix not available or invalid
1	GPS SPS Mode, fix valid
2	Differential GPS, SPS Mode, fix valid
3	GPS PPS Mode, fix valid

## 4.2 GLL-Geographic Position - Latitude/Longitude

For example:

\$xxGLL , 3723.24755, N,12158.34161, W,161229.487, A\*2C

Field	Name	Example	Units	Description
1	Message ID	\$xxGLL		GLL protocol header
2	Latitude	3723.24755		ddmm.mmmm
3	N/S Indicator	N		N=north or S=south
4	Longitude	12158.34161		dddmm.mmmm
5	E/W Indicator	W		E=east or W=west
6	UTC Position	161229.487		hhmmss.sss
7	Status	A		A=data valid or V=data not valid
8	Check sum	*2C		
9	<CR> <LF>			End of message termination

## 4.3 GSA – GNSS DOP and Active Satellites

For example:

\$xxGSA , A, 3, 07, 02, 26,27, 09, 04,15, , , , , 1.8,1.0,1.5\*33

Field	Name	Example	Units	Description
1	Message	\$GPGSA		GSA protocol header
2	Mode 1	A		See Table 1-2
3	Mode 2	3		See Table 1-3
4	Satellite Used	07		Sv on Channel 1
5	Satellite Used	02		Sv on Channel 2
6	...	...		...
7	Satellite Used			Sv on Channel 12
8	PDOP	1.8		Position Dilution of Precision
9	HDOP	1.0		Horizontal Dilution of Precision
10	VDOP	1.5		Vertical Dilution of Precision
11	Check sum	*33		
12	<CR> <LF>			End of message termination

Table 1-2

Value	Description
M	Manual- forced to operate in 2D or 3D mode
A	Automatic-allowed to automatically switch 2D/3D

Table 1-3

Value	Description
1	Fix not available
2	2D
3	3D

## 4.4 GSV - GNSS Satellites in View

For example :

\$xxGSV , 2, 1, 07, 07, 79,048, 42, 02, 51,062, 43, 26, 36,256, 42, 27, 27, 138,42\*71

\$xxGSV, 2, 2, 07, 09, 23,313, 42, 04, 19, 159, 41, 15,12,041, 42\*41

Field	Name	Example	Units	Description
1	Message ID	\$xxGSV		GSV protocol header
2	Number of Message	2		Range 1 to 3
3	Message Number	1		Range 1 to 3
4	Satellites in View	07		
5	Satellite ID	07		Channel 1(Range 1 to 32)
6	Elevation	79	degrees	Channel 1(Maximum 90)
7	Azinmuth	048	degrees	Channel 1(True, Range 0 to 359)
8	SNR(C/NO)	42	dBHz	Range 0 to 99,null when not tracking
9	...			...
10	Satellite ID	27		Channel 4(Range 1 to 32)
11	Elevation	27	degrees	Channel 4(Maximum 90)
12	Azimuth	138	degrees	Channel 4(True, Range 0 to 359)
13	SNR(C/NO)	42	dBHz	Range 0 to 99, null when not tracking
14	Check sum	*71		
15	<CR> <LF>			End of message termination

## 4.5 RMC - Recommended Minimum Specific GNSS Data

Structure:

\$xxRMC, 161229.487, A, 3723.24751, N, 12158.34161, W, 0.13,309.62, 120598,, \*10

Field	Name	Example	Description
1	Message ID	\$xxRMC	RMC protocol header
2	UTS Position	161229.487	hhmmss.sss
3	Status	A	A=data valid or V=data not valid
4	Latitude	3723.24751	ddmm.mmmmm
5	N/S Indicator	N	N=north or S=south
6	Longitude	12158.34161	dddmm.mmmmm
7	E/W Indicator	W	E=east or W=west
8	Speed Over Ground	0.13	
9	Course Over Ground	309.62	True
10	Ground		
11	Date	120598	dummy
12	Magnetic variation		E=east or W=west
13	Check sum	*10	
14	<CR> <LF>		End of message termination

## 4.6 VTG - Course Over Ground and Ground Speed

Structure:

\$xxVTG, 309.62, T, M, 0.13, N, 0.2, K\*6E

Field	Name	Example	Description
1	Message ID	\$xxVTG	VTG protocol header
2	Course	309.62	Measured heading
3	Reference	T	True
4	Course		Measured heading
5	Reference	M	Magnetic
6	Speed	0.13	Measured horizontal speed
7	Units	N	Knots
8	Speed	0.2	Measured horizontal speed
9	Units	K	Kilometer per hour
10	Check sum	*6E	
11	<CR> <LF>		End of message termination